

# Button-Guard+



A unique range of buttons and switches that are fully protected, the range that you can count on.

## 2 or 3 Position Key Switch Options

### Why use Button-Guard+ ?

The new 'All in One' protective enclosure specifically designed to give the added protection to vulnerable range of buttons and switches that is ultimately need. Lead the fight back against environmental failure, accidental activation, vandalism or unnecessary damage.

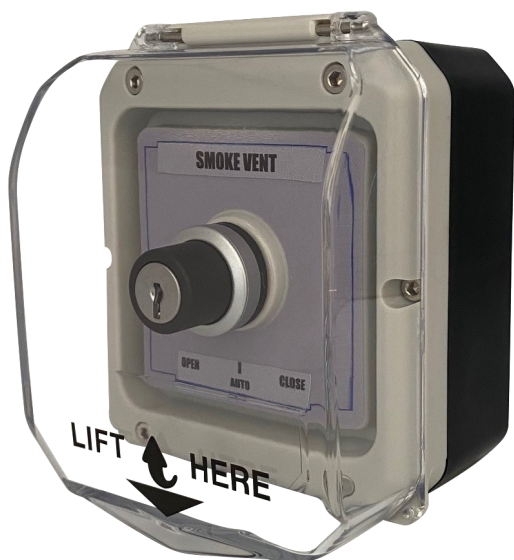

### Key attributes:

- Surface Mount (not retrofit)
- Weatherproof
- Break-Seal Mounting Area
- High Impact Protection (from both front & side)
- UV Stabilised (prolongs life from UV rays)
- Manufactured in Robust Polycarbonate
- Flexible wording options ('Apply Yourself' labels)

### Product Dimensions in MM's

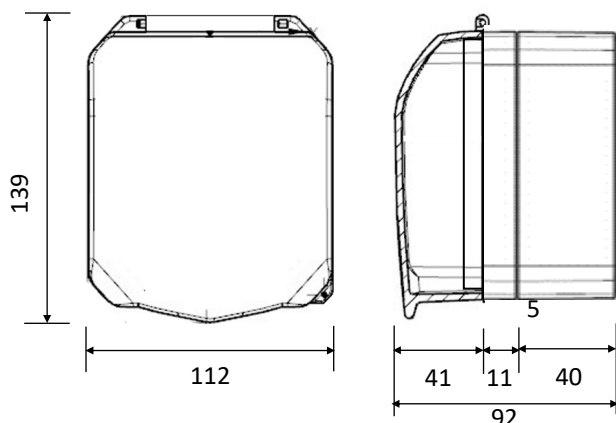

These everyday issues can be a crippling cost to any business and potentially unrecoverable. Prevent downtime, eliminate false shutdowns, evacuations, but help save and protect your business and your life

Button-Guard+ allows you the flexibility when choosing the button or switch you require, it then provides the ultimate protection it needs, from the environment and or from unwanted activations.

Simply choose from a extensive range of:

- Emergency push buttons,
- Standard push buttons,
- Selector switches,
- Key switches,
- Industrial ON/OFF buttons,

Then allow the Button-Guard+ to be your best line of defence

### Strength & Durability

The **Button-Guard+** is small, incredibly strong and robust, its construction helps protect from hard hitting impacts from the front or from the side and also defends against 2 problematic everyday issues. Firstly protecting the covering product from the ingress of water and dust especially when the installation is within a harsh / industrial environment and secondly to defend the covering product against accidental activation or even targeted misuse.

### UV Stabilisation

Manufacture in UV stabilised polycarbonate it will become your first line of defence, having the ability to protect against extreme environmental conditions, hard hitting impacts from the front or from the side.

### Application areas:

Industrial Application Areas, Outdoors Areas, Washdown Areas, Sauna's and Pool Areas etc.....

### 'Apply Yourself' Instructive Labels - allowing flexibility:

The product comes complete with 'Apply yourself' instructive labels, to allow you to provide the correct wording or text depending on the application.

### 20mm Threaded Inserts



The rear back section has 20mm entry points on both the top and the bottom surfaces, giving you the ability to rotate the back box depending on the installation circumstances.

- For further colour options and ordering codes (see over)

**Type: Latching (stay-put) 2 or 3 position Operation – Non illuminated**



Product Code:  
**BG-KS-L-2-2-0**

Description:  
Button Guard+ with 2 Position Key Switch, Latching (stay-put), N.O & N.C. contact, Removeable key



Product Code:  
**BG-KS-L-3-2-0**

Description:  
Button Guard+ with 3 Position Key Switch, Latching (stay-put), N.O. & N.C. contact, Removeable key



### Key Switch Specifications:

|                               |                        |
|-------------------------------|------------------------|
| Button Type:                  | Key selector switch    |
| Material:                     | Plastic                |
| Position:                     | 2 position/3 position  |
| Operation mode:               | Spring return/Stay put |
| Contact:                      | N/O+N/C                |
| Protection Grade:             | IP62                   |
| Rated insulation:             | AC 600V(50Hz/60Hz)     |
| Insulation resistance:        | ≥50MΩ                  |
| Conventional heating current: | 10A                    |
| Contact resistance:           | ≤25MinΩ                |
| Insulation resistance:        | ≥50MΩ                  |
| Pf withstand voltage:         | AC 2.5KV/min           |
| Contact resistance:           | ≤25MinΩ                |
| Voltage wave:                 | ±20%                   |
| Mechanical life:              | 100x10 <sup>4</sup>    |
| Electrical life:              | 500x10 <sup>4</sup>    |
| Continuous working life:      | 10x10 <sup>4</sup> h   |

### 'Apply Yourself' Instructive Labels:

Each individual Button-Guard+ product will automatically come with a selection of 'Apply Yourself' labels designed to allow added flexibility, there are even blank labels that easily be written on too.

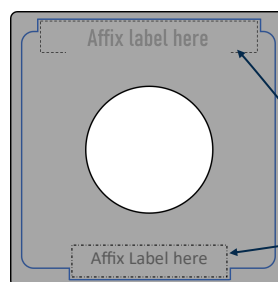

Once you have chosen and selected the required label(s), peel them off the sheet and affix the label(s) onto the product



**Primary Text Label Options:**  
FIREMANS KEYSWITCH • EXTRACT • OVERRIDE • MANUAL EXTINGUISHANT DISABLE • EMERGENCY DOOR RELEASE • SMOKE VENT • VENTILATION

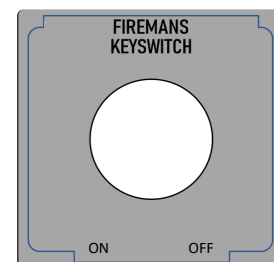

**2 Position Operation labels:**  
ON / OFF • OFF / ON • CLOSE / OPEN • OPEN / CLOSE • EXTRACT / NORMAL • OVERRIDE / NORMAL • START • SHUT OFF • RELEASE • START / STOP

**3 Position Operation labels:**  
AUTO / ON / OFF • EXTRACT / OFF / NORMAL • OPEN / AUTO / CLOSE

**Blank Label Options:**  
If you cannot find the text you require there are also blank labels available to choose from, these can easily be written on by hand before affixing to the product if desired.

### Ultra Guard+ Operation Label



Each protective Ultra Guard+ enclosure comes complete with an fully instructive, translucent operation label.

Easy to follow in case of an emergency or if legitimate activation is required

### Additional Security Option—Break seal Facility

Break seal mounting holes are positioned on the lower right hand corner of the cover and the central coloured chassis., apply an 'easy break' break-seal through the hole to give addition security or deter unwanted tampering

### Ultra-Guard+ Accessories:

UG-BR-10 Ultra-Guard Replacement Break-seals, Pack of 10

